

# inoleds

Arc Floor Lamp Black / White

Lampadaire Arc Design Intérieur Noir/Blanc

Model FL138 / Modèle FL138



**Thanks for your purchase.**

For any inquiries, contact us at [hello@inoleds.com](mailto:hello@inoleds.com) or on our website [www.inoleds.com](http://www.inoleds.com)

**Merci d'avoir passé votre commande et de votre confiance.**

Veuillez bien lire les instructions et les consignes de sécurité avant utilisation.

N'hésitez pas à nous contacter pour plus de renseignement à [hello@inoleds.com](mailto:hello@inoleds.com)

Importé par / Imported by OUI SMART  
15 RUE DES HALLES  
75001 PARIS, FRANCE  
[www.inoleds.com](http://www.inoleds.com)  
[www.inoleds.fr](http://www.inoleds.fr)



Lire les instructions  
avant utilisation



CE

Made in China  
FABRIQUE EN  
CHINE

**EN**

Please read the instructions carefully and keep them for future reference. If you need further assistance, please contact us via email.

material : Aluminium+metal

size : 320\*1200\*1700mm

Voltage : AC220-240V/50-60Hz

Power : 24W

Warranty : 2 years

## What's in the box



## Installation

1. Connect the two terminals on the lamp body.
2. The M10 screw passes through the iron plate and is locked with a nut.
3. Tear off the yellow film of the sponge pad and stick it to the underside of the lamp base.
4. Connect the lamp body and the adapter terminal.
5. Complete the installation, plug in and turn on.



Step 1



Step 2

**EN**



Stick the sponge pad



Fix the iron plate and the light pole,  
and tighten the nut

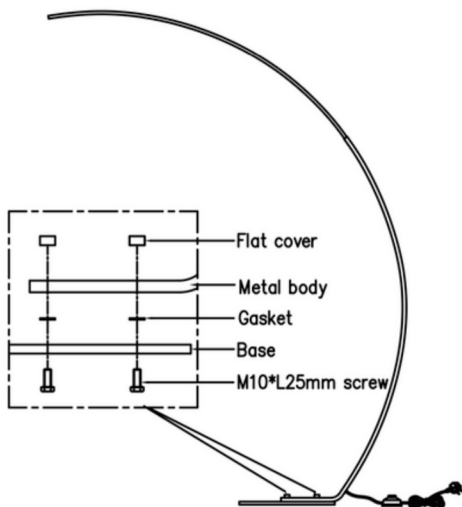

### Package

Flat Cover \*2  
Iron Plate \*1  
Power Adapter \*1

Gasket \*2  
Remote Control \*1  
User Manual \*1

Wrench \*1  
LED Light \*1

**FR**

Veillez lire attentivement les instructions et les conserver pour référence ultérieure. Si vous avez besoin d'une assistance supplémentaire, veuillez nous contacter par e-mail.

Matériaux: Aluminium+metal

Taille : 320\*1200\*1700mm

Voltage : AC220-240V/50-60Hz

Power : 24W

Garantie : 2 ans

### Installation

1. Connectez les deux bornes sur le corps de la lampe.
2. Verrouillez 2 vis hexagonales intérieures avec une clé.
3. La vis M10 traverse la plaque métallique et est fixée avec un écrou.
4. Retirez l'adhésif jaune et collez-le au bas du support de lampe.
5. Connectez le corps de la lampe et la borne de l'adaptateur.
6. Terminez l'installation et branchez.



Étape 1



Étape 2



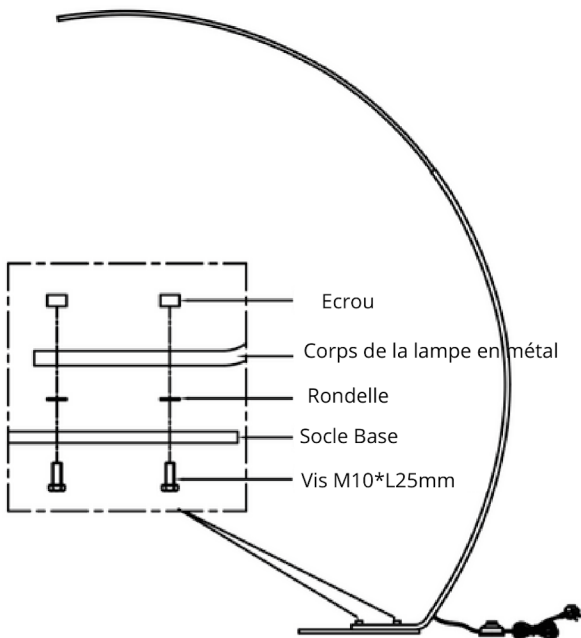

## Emballage

Ecrou vis \*3 (2+ 1 extra)

Socle base en Acier\*1

Adaptateur secteur \*1

Corps del la lampe \*1

Télécommande \*1

Manuel d'utilisation \*1

Clé plate \*1

Lumière LED \*1

Up to 15m control range, you can control the lamp even in the sofa or warm bed with the remote.

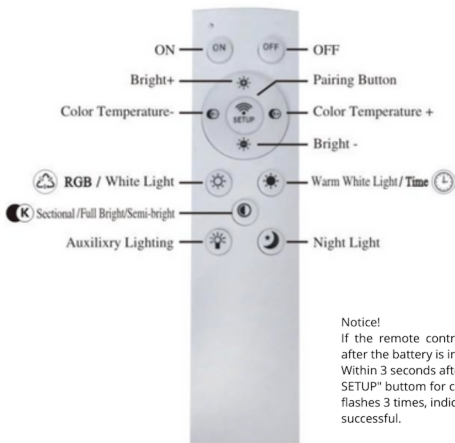

#### Notice!

If the remote control of the product cannot be used after the battery is installed.

Within 3 seconds after turning on the light, long press "SETUP" button for code alignment. The light on the key flashes 3 times, indicating that the code matching is successful.



Press this button once in 10 seconds after the lamp has been powered on

#### CODING MODE

After the lamp is electrified, press the SETUP key (code key) on the remote control quickly in 10 seconds. The light flashes indicate the code is successful. Otherwise, turn off the total power supply of the lamp and then re-operate this step until the light flashes and the alignment is successful.



Long press or click this button, brightness will increase



Long press or click this button, brightness will reduce



Long press or click this button, the color temperature increases, and the light color turns white.



Long press or click this button, the color temperature drop, and the light color turns warm.



Press this button, the lamp turns into warm light (3000K)



Press this button, the lamp turns into white light (5700K)



Click this button to switch the color temperature between white light, warm light and neutral light.



Press this button to switch the lamp between full power and half power, and the color temperature of the lamp is neutral light.

Avec la télécommande, vous pouvez facilement contrôler la lampe sans quitter le canapé - 15m de distance.

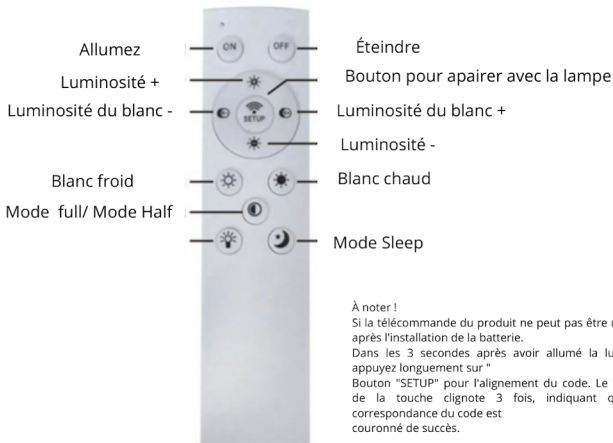

Press this button once in 10 seconds after the lamp has been powered on

CODING MODE

After the lamp is electrified, press the SETUP key (code key) on the remote control quickly in 10 seconds. The light flashes indicate the code is successful. Otherwise, turn off the total power supply of the lamp and then re-operate this step until the light flashes and the alignment is successful.



Long press or click this button, brightness will increase



Long press or click this button, brightness will reduce



Long press or click this button, the color temperature increases, and the light color turns white.



Long press or click this button, the color temperature drop, and the light color turns warm.



Press this button, the lamp turns into warm light (3000K)



Press this button, the lamp turns into white light (5700K)



Click this button to switch the color temperature between white light, warm light and neutral light.



Press this button to switch the lamp between full power and half power, and the color temperature of the lamp is neutral light.

**EN**

## Safety instructions

Please read this instruction manual carefully and conserve it for reference for as long as you use this product. This light is guaranteed to be safe provided that the instructions below are followed. The manufacturer shall not be liable for any damage from incorrect assembly or use.

- Power must be disconnected before assembly, maintenance, or cleaning. Check that the electrical specifications of this light are compatible with your installation.
- This light is designed solely for interior use, except for damp rooms.
- Care should be taken not to damage the cables during assembly. If the external cable or the cord of this light are damaged, they must be replaced by the manufacturer, the manufacturer's maintenance service, or by equivalent qualified personnel, to avoid any risks.
- Keep out of reach of children.
- Never stare at the LEDs, a direct and prolonged exposure could cause damage to eyesight.

## INSTRUCTIONS FOR WASTE DISPOSAL

This device must not be disposed of in the trash.

**FR**

## Conseils de sécurité

Ce mode d'emploi vous apprend à vous servir correctement du produit. Gardez-le précieusement afin de pouvoir le consulter à tout moment.

- N'utilisez l'appareil que comme indiqué dans la notice. Aucune garantie ne pourra être appliquée en cas de mauvaise utilisation du produit.
- N'ouvrez pas l'appareil, sous peine de perdre toute garantie.
- N'essayez pas de réparer l'appareil vous même.
- Faites attention lorsque vous manipulez votre produit. Une chute ou un coup peuvent l'abîmer.
- Ne l'exposez pas à l'humidité et à la chaleur.
- N'utilisez l'appareil que comme indiqué dans la notice. Aucune garantie ne pourra être appliquée en cas de mauvaise utilisation du produit. Nous ne sommes pas responsables des conséquences inhérentes à un dommage. Le fabricant se réserve le droit de modifier les caractéristiques techniques entraînant ainsi des erreurs dans ce manuel.

## INDICATIONS CONCERNANT L'ÉLIMINATION DE DECHETS

Cet appareil ne doit pas être jeté à la poubelle.

INOLEDs branded items purchased from inoleds.com include 2 years limited replacement warranty. For Customer Service, please contact us via email [hello@inoleds.com](mailto:hello@inoleds.com)

The Inoleds® name and logo are registered trademarks.

©INOLEDs. All Rights Reserved.

Les articles de la marque INOLEDS achetés sur inoleds.fr bénéficient d'une garantie limitée de remplacement de 2 ans. Pour le service clientèle, veuillez nous contacter via email [hello@inoleds.com](mailto:hello@inoleds.com)

La marque INOLEDS et le logo INOLEDS® sont des marques déposées.

©INOLEDs. Tous droits réservés.

Importé par / Imported by OUI SMART

15 RUE DES HALLES  
75001 PARIS, FRANCE

[www.inoleds.com](http://www.inoleds.com) / [www.inoleds.fr](http://www.inoleds.fr)



Lire les instructions  
avant utilisation



Made in China  
FABRIQUÉ EN  
CHINE